

energeto 8000ED

- Offset design
- 85 mm construction depth
- 6-chamber profile with 3 seals

U_w-Value
≥ 0.72

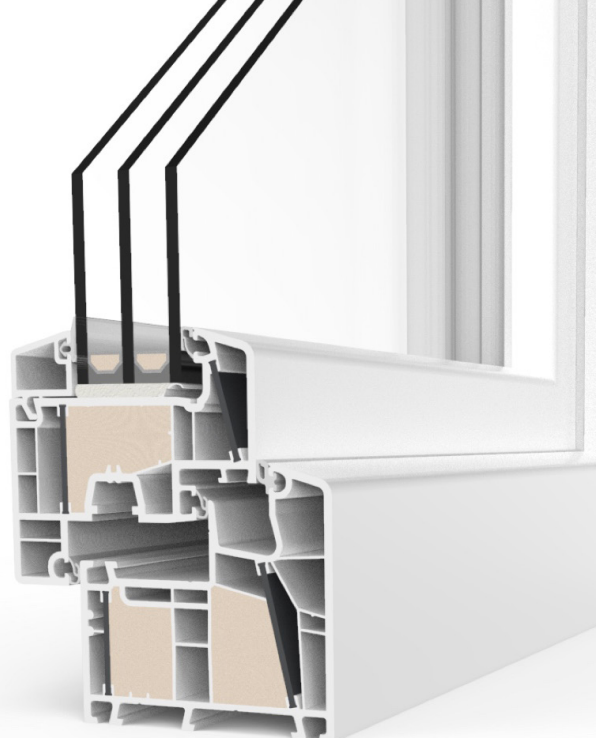

Energy saving through new windows

U _w value (old)	3.50 W/(m²K)
U _w value (new)	0.72 W/(m²K)
Window area	30 m²
Annual fuel oil savings	1109 litres
Annual carbon dioxide reduction	2,996 kg

Explanation

Heating degree days	4,050
Conversion factor kilogram into litres of heating oil	1.19
Conversion of calorific value Wh/kg	11,800
Heating efficiency	0.75

COLOURS

- White
- Decor according to current price list according to colour range uPVC

SOUND INSULATION

Window R_wP up to 41 dB

GLASS THICKNESS

To 51 mm

SEALS

- Centre sealing system
- 3 sealing levels
- Possible colours:
 - Papyrus white or black for decor

SAFETY EQUIPMENT / FITTING

BASIS:

- Bonding technology
- Fitting with 3 locking plates
- 3-dimensionally adjustable
- Anti mishandling device
- Sash lifter
- Max. sash weight 90 kg

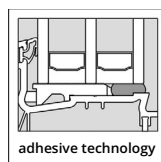

OPTIONAL:

- ActivPilot Comfort PAD (parallel stop fitting)
- Safety levels: RC1, RC2, according to EN 1627-1630
- SELECT fitting (concealed corner and shear bearings)
- "Tilt before Turn"
- High Control (magnetic contact for electronic monitoring)



SYSTEM VALUES

- Air permeability: Class 3 (according to EN 12207)
- Driving rain-proof: Class 4A (according to EN 12208)
- Water tightness against driving rain:
Class B3 (according to EN 12210)

Please note:

The classes given here are minimum classes. For higher requirements please consult us.

THERMAL INSULATION

- Reference size 1230 x 1480 mm
- $U_f = 0.79 \text{ W/(m}^2\text{K)}$
- Minimum requirement according to GEG2020 $U_w = 1.3 \text{ W/(m}^2\text{K)}$
- PHT = suitable for passive houses

U_g Glass (W/m ² K) according to EN 673	U_w window (W/m ² K) Type of edge spacer		
	Aluminium	KSH / KSD	Swisspacer Ultimate
Double glazing	Psi = 0.066 (W/mK)	Psi = 0.041 (W/mK)	Psi = 0.032 (W/mK)
1.1	1.17	1.10	1.08
1.0	1.10	1.03	1.01
Triple glazing	Psi = 0.064 (W/mK)	Psi = 0.039 (W/mK)	Psi = 0.030 (W/mK)
0.8	0.97	0.89	0.87
0.7	0.90	0.82	0.80
0.6	0.83	0.76 (PHT)	0.74 (PHT)
0.5	0.77 (PHT)	0.69 (PHT)	0.67 (PHT)

U_w values < 1.0 W/(m²K) are shown with two decimal places in accordance with EN ISO 10077

U_w values > 1.0 W/(m²K) are shown with one decimal place according to EN ISO 10077, here with two decimal places for information purposes

The PSI values given are taken from the data sheets of the "Warm Edge" working group

SOUND INSULATION

Reference size 1230 x 1480 mm
(Elements with test certificate)

$R_w \triangleq R_{wp}$ = test value window	R_{wr} = calculated value window	R_{wp} = test value glass	Test certificate no.
33 dB	31 dB	29 dB	175 42480/2
38 dB	36 dB	35 dB	175 42480/2
41 dB	39 dB	42 dB	175 42480/2

For Germany, the following applies according to DIN 4109:1989-11:
 R_w corresponds to R_{wp} ; $R_{wr} = R_{wp} - 2\text{dB}$

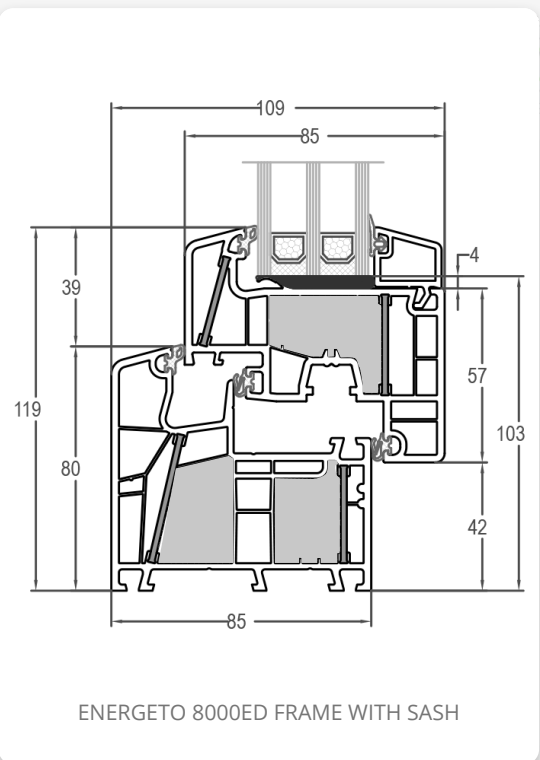

ENERGETO 8000ED FRAME WITH SASH

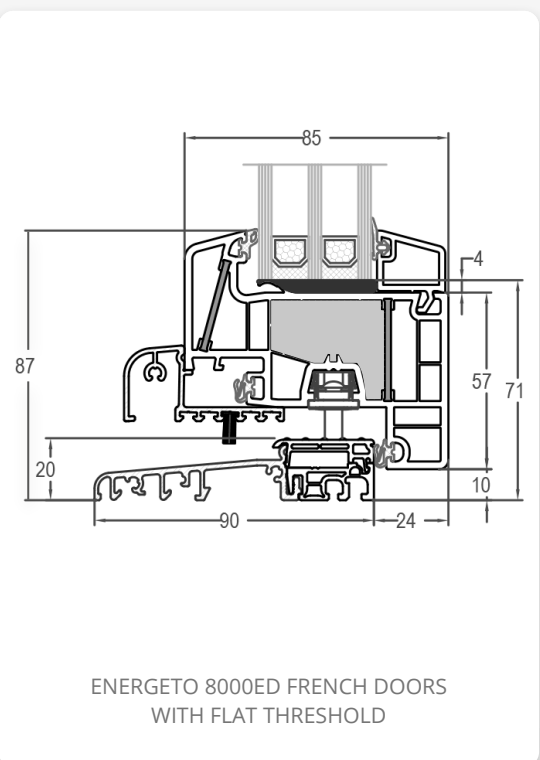

ENERGETO 8000ED FRENCH DOORS WITH FLAT THRESHOLD

POSSIBLE GLASS STRIPS:

STANDARD

